

REED MAKING GUIDE

2024

There are four parts of the reed making process.

1. *FORM THE TUBE*
2. *BEVEL + WIRES*
3. *WRAP TURBAN WITH THREAD OR HOT GLUEGUN*
4. *FINISH REED: CUT TIP & SCRAPE.*

Before starting part 1, you must soak your cane.

SOAK CANE

1. Lightly sand the back of cane with *400 grit sandpaper*.
2. Soak cane in water for 8-12 hours.

PART 1 OF FORMING THE TUBE

TOOLS: *GSP Cane, ruler, xacto knife, pliers, forming mandrel, 22-gauge brass wire, dowel rod, cotton string, 400 grit sandpaper, drying rack.*

SCORE THE TUBE (*xacto knife blade #11 & dowel rod*)

1. Start a few millimeters from the collar. Put a single score mark in the very center. When you get to the very bottom, cut all the way through the bark.
2. Then do 2 cuts from either side then go all the way through at the bottom. Try to get them as evenly spaced as you can. You should have approximately 5-7 score marks.
3. Repeat the same process on the other end then re-soak cane.

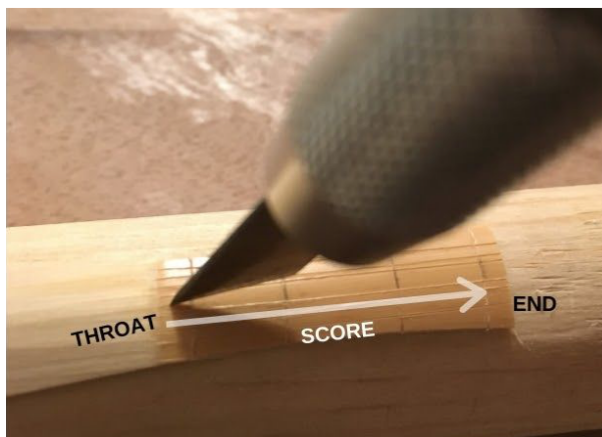

FOLD THE CANE (*ruler*)

1. Measure & mark the center of cane.
2. Fold cane over the center mark with the edge of ruler
2. To close the tip, crimp the center of cane with fingers
3. Check the alignment of the sides then re-soak cane.

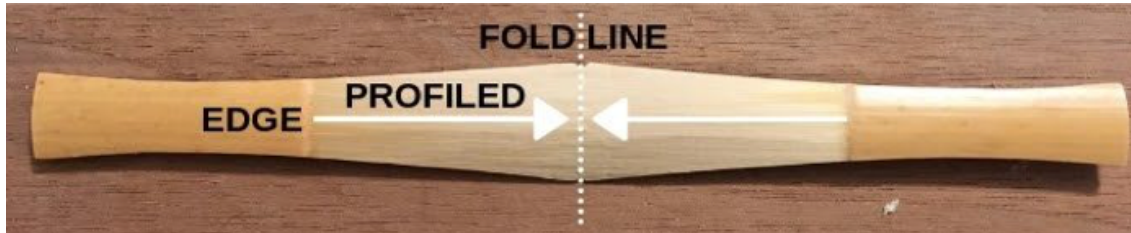

WIRE 1 INSTALLATION (near collar) (*wire, pliers & ruler*)

1. Cut one piece of wire then straighten & smooth wire.
2. Measure 26mm from butt of reed and mark line with pencil.
3. Fold cane and align the sides or edges making them parallel with no overlap.
4. How to Install wire 1 (PAGE 2 REED DIAGRAM)
 - Put first wire on by placing wire behind folded cane at the first wire mark.
 - Wrap left side over right keeping left side on top at all times.
 - Wrap around once and bring both wires together facing you to form a small isosceles triangle at the center point of cane width.
 - Pull, let go then twist wires in a clockwise direction using pliers.
 - Remeasure 26mm from the butt end of the reed to the bottom of the wire.
 - **DON'T PULL AND TWIST AT THE SAME TIME!!!**
 - Always pull first to take up slack in wire.
 - Make sure the sides of reed have not slipped and get them as even as possible.
 - Trim off the excess twisted wire.

WRAP COTTON STRING (*forming mandrel & pliers*)

- Wrap string very tightly above first wire 5-6 wraps
- Wrap string loosely below the 1st wire down the base of the tube. Tie a knot on butt end.
- Soak the reed until completely wet.
- Heat water in microwave for 1:30 minutes in steaming hot water then soak forming mandrel and reed in water until mandrel is hot to touch.



FORM REED ON FORMING MANDREL

- Using forming mandrel (long tip), push tip straight into tube **without twisting**. Push until it gets hard to push.
- Take your pliers and gently round the first wire from the sides.
- Around the butt end, crush with pliers 6-7 mm. This is going to round the tube. Keep going around the tube. Push reed on forming mandrel a little more then crush with pliers at butt end again until the tube is perfectly round.

PLACE REEDS ON DRYING RACK FOR 2 DAYS – 2 WEEKS!!

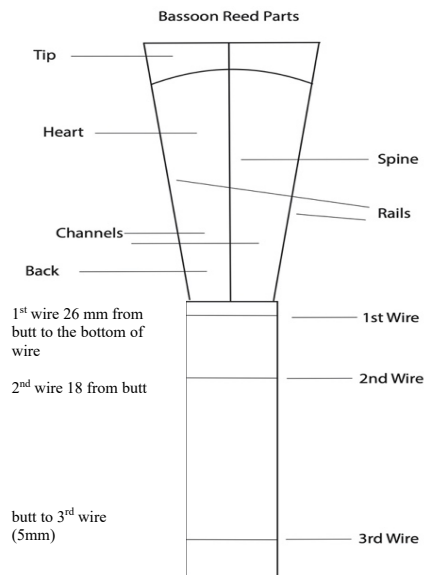

Measure & mark the wire dimensions with pencil from bottom of tube towards the collar.

WIRE INSTALLATION ORDER 2-3-1

Twist wires 1 & 3 on the same side. Wire 2 is twisted on the opposite side.

PART 2 BEVELING & WIRES

TOOLS: cut 3"x3" 320 grit sandpaper, cut 3 pieces of wire (clip 3rd wire longer), pliers, forming mandrel, cotton thread

BEVELING

1. Remove cotton thread and wire 1
2. With pencil Mark 10mm from edge of sandpaper.
3. Sand the reed as flat as you can up to the 10mm mark until the edges are flattened.
4. The longer the bevel, favors the high register, the shorter the bevel favors the low register.

WIRE 2

1. Mark & measure 18mm from butt of reed to the bottom of the wire
2. Align the edges and sides.
3. Gently wrap cotton thread around the collar area. It helps keep the reed in place.
4. Put the reed back to the line on the forming mandrel.
5. 2nd wire goes on the same way as part 1.
6. Pull & Twist
7. Remeasure wire 2

WIRE 3

1. Mark & measure (6mm) to the middle of the wire from the butt. (Bill Williams 3mm from butt)
2. Wrap reed opposite side of wire 2; two times around base of tube.
3. Rough it out & remeasure 5mm from the butt.
4. With pliers, squeeze around the butt.
5. If the sides are not closed or sealed, move the reed up on the forming mandrel then continue tightening the wire snug.
6. The longer the distance between wires 2 & 3 the darker the reed. The shorter the distance the brighter the reed.
7. Make sure the sides are sealing.

WIRE 1

1. Mark & measure (26mm) from the butt end to the bottom of the first wire (not to the center).
2. Pull & twist with less pressure. You don't want to pinch the cane.

SOAK THE REED

1. Completely submerge the reed in water.
2. Let reed dry over night.

PART 3 RETIGHTEN WIRES & FORM TURBAN

TOOLS: *pliers, forming mandrel (long tip), holding mandrel, ruler, Duco Cement, thread*

TIGHTEN WIRES ON FORMING MANDREL

1. Remeasure wires.
2. Tighten wires in this order: **2 – 3 – 1** on forming mandrel
3. Position butt end closest to the first line.
3. Round tube below the 3rd wire with pliers

TURBAN (forming mandrel, glue, thread)

1. Once wires have been tightened, cover bark with duco cement below the 2nd wire.
2. **Remember!!! Do not cover the 2nd wire with glue!!!**
3. Let reed dry over night before starting the finishing process.
4. 3/8" Heat shrink tubing is another turban method.

PART 4 REAM/CLIP THE TIP/THE FIRST SCRAPE

REAMING THE BLANK

1. Ream dry.
2. Ream to line on forming mandrel.

CLIP THE TIP

1. Soak the reed in water a few minutes.
2. Measure & mark 31-29.5 mm from the top of the first wire
3. Clip with end nippers

SAND CORNERS & BLADES

1. Gently sand corners a little bit with sandpaper to a 45 degree angle.



THE FIRST SCRAPE

1. **TIP:** Use a reed knife and sandpaper. It should be fairly thin for response.
2. **WINGS:** Use a knife & diamond file. Make sure it scrapes thick to thin. Thicker from heart towards the corners of reed.
3. **CHANNELS:** Scrape all the way from the back, up to the wings with a reed knife.
4. **BACK:** Scrape as much needed to even out the back. Sand light the spine and heart to balance the reed.

DAY TWO SCRAPE

1. Scrape again the tip and wings with **knife**.
2. Blend tip & wings with sandpaper or **file**.
3. Blend rails & channels with **file**. Thick to thin.
4. Unresponsive low register scrape the rails in the back 3rd

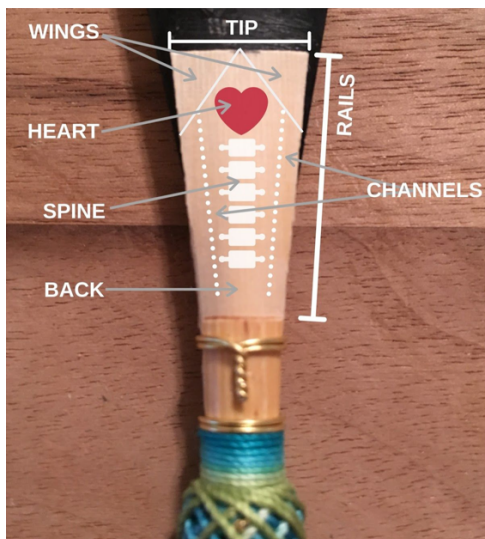

Reed Adjusting: by Christian Davidsson

You can spend a lot of time scraping and adjusting reeds with no or only minimum results. You can also spend minimum time with maximum results. Then, of course, you have to know where to scrape or adjust etc. But the most important thing is that you have a methodical approach so that you have an overview while paying attention to what you are doing, thereby learning from your mistakes, and developing your knowledge and your skills in order to have the reeds the way you want them.

Diagnosis. First the reed you are about to adjust needs a diagnosis. It is not enough that you discard the reed just thinking it is bad, because the most impossible reed can have a happy ending and vice versa. OK, the reed doesn't feel good, but what is it about it that doesn't feel good? It could be one or more things and sometimes it could just be a big mess. If it is only e.g. the striking of a note that isn't good, you head for scraping/adjusting the area or areas that influence the striking/tonguing. But if it is more, it is time for being methodical and solve the problem bit by bit. When you play on a reed you could probably say immediately if the reed is too hard, too soft, too dark, too bright, too heavy in the high register, too heavy in the low register, too sparkling etc. You take measures to correct all the problems in the order that they reveal themselves.

Balance. It is important to know that all things are related and that it is the balance between all corrections that will give you a better reed. To point out that if you scrape here the result will be this and if you scrape there the result will be that is the easy part, which I will show in the following figures. The more difficult part is to achieve a balance in the reed, which you will have either with pure luck or if you develop your feeling for how much of one thing or another you should do to your reeds. This feeling for the reeds you can only develop yourself. However, with great help from being strategic, not scraping too much at one time and the following reed-scraping figures, in time you can further develop through your own discoveries.

Scrape with your eye! See to, no matter where you scrape, that you don't get any pits or edges. It should be soft crossings from the areas where you adjusted to the non-adjusted ones. Balance between the middle of the reed to the edges. Too thick in the middle and too thin at the edges e.g. will give you a reed that is all-through resistant. Use your eye and see to that there is flow, harmony and smoothness through the whole reed. Get to know how different cane reacts to similar scrapings. Always let the qualities you are satisfied with remain untouched and be the reference points to the things you aren't satisfied with.

In the following description I outline different ways of approaching that which your reed lacks.

This doesn't mean that you should apply all the remedies for each point, do that only in the worst cases. The measures described are in an order that I find suitable. Alternate between the different ways to reach the desired goal as all corrections have their side effects and some of these side effects can be put in balance to achieve that which you wish with your reed.

If the reed is too hard: see that the middle of the reed (**15**) isn't too thick in comparison to the edges, if so, scrape here. If you have too much wood in your reed, start to scrape evenly over the whole reed (**8**). Try to discern if the e.g., high register becomes light and the low becomes heavy or vice versa. Then stop and do some further scraping on the areas you are not satisfied with. If the

cane is very hard, you can as a last resort dip the whole reed **(8)** in boiling water for approx. 10 secs.

Too soft: If the reed is only partly soft, try to pull and tighten the first and second rings **(10)**, **(11)**. If it is not enough, pinch up the reed on both sides just behind the first ring at point **(14)**. If the reed is very soft, then cut the tip about 0,5 -1,0 mm.

Too heavy in the low register: Scrape the back part **(3)**. You can also pinch the second ring under and over **(13)**. To a certain extent it helps to scrape the outer corners on point **(18)**, but it also makes the high notes easier. Point **(1)** makes the lows somewhat easier, but mainly makes the whole reed freer.

Too heavy in the high register: Scrape at point **(21)**. Tighten and pinch the second ring on both sides **(11)**. Scrape at point **(2)**, but if not enough even at point **(7)** and **(18)**. If required, ream out the reed or cut it.

Too dark sound: Start scraping the tip evenly all over **(9)**. See that the "heart" at point **(4)** isn't too thick compared to the surrounding areas. Just take a little at a time here since you lose "sound" and stability but on the other hand gain more freedom and flexibility. If even more is needed, proceed to point **(7)**. Pinch both sides of the reed at the second ring **(11)**. Finally, drag the knife in one stroke along the reed on each side of the absolute middle **(19)**. This scraping should be done as a last resort and not too much.

Too bright or too sparkling: Scrape down the edges on both sides **(6)**. Even at point **(1)** that goes further towards the middle makes the reed darker. Pinch with a pliers on both sides of the reed, behind the first ring at point **(14)**. The reed will have a larger opening that you squeeze together with your fingers in front of the first ring. You will also have increased resistance by pinching at point **(14)**. Further, pinch over and under the second ring **(13)**.

Too hard tonguing: Scrape with a knife the outer side of the tip **(5 and 7)**. Point **(9)** will give you easier striking and larger flexibility. Also try the points at **(1)** and **(4)**.

Too easy tonguing: Pinch together the reed with your fingers and grind (with wet-strength sandpaper P1000) the front edge of the tip **(17)** or cut the reed 0,5 mm. Tighten the first ring **(10)**. Further scrape at point **(21)**. You can also pinch the reed on both sides at point **(14)**.

Too low in the high register: Ream out the reed or cut it. Pinch on both sides of the reed at second ring **(11)** and/or pinch together the reed at the first ring, point **(12)**.

Too high in the low register: Pinch together the reed at second ring **(13)**. Scrape at point **(1)**, and if needed at point **(3)**. Scrape at point **(16)**, the "eyes".

What happens when scraping or adjusting the different points?

There is a lot to be said about this and a great deal you will notice yourself. I will describe in general terms what basically happens.

1) Scraping here gives you a freer reed. The sound gets slightly darker, and the low is increased.

- 2)** Tonguing becomes easier. Better flexibility over the whole register. Intruding sounds are muted.
- 3)** The low register becomes easier.
- 4)** The "Heart", the core of the tone. Too little in this area makes the reed collapse and too much gives you a heavy reed with bad striking and un-flexibility when playing legato. Try other measures before scraping here but if you must scrape, then just a little at the time. The tone gets brighter and weaker but freer when you scrape here.
- 5)** Tonguing becomes easier as well as playing pianissimo in the upper registers.
- 6)** Scraping along the edges dampen the sound with a slightly darker tone. The reed becomes more flexible. If you take too much here in comparison to the middle of the reed, an imbalance arises and the reed becomes unstable, stiff, and resistant.
- 7)** Gives an easier high register and tonguing. You also get a brighter sound.
- 8)** If you grind evenly over the whole reed, it will retain its internal relationship to itself and will become lighter.
- 9)** Makes the high register easier, improves the striking, gives a brighter sound and more flexibility.
- 10)** The sides of the first ring. The first ring shouldn't be pulled too tight as it restrains the vibrations of the reed. If it is pulled too hard and you want a freer reed, just loosen it up a bit. By pinching the reed on both sides you will have a larger opening, more resistance, a darker sound, and easier low register.
- 11)** The sides of the second ring. The second ring should be relatively firmly pulled. Pinch on both sides and you will have a smaller opening, greater stability and easier high register.
- 12)** Over and under of the first ring. Pinch the reed together here and you will have a smaller opening, brighter sound and easier high register.
- 13)** Over and under of the second ring. Pinch here and you will get a larger opening, more volume, easier legato, a darker sound and easier low register.
- 14)** The sides behind the first ring. Pinch here and you will get a darker sound, more resistance and stability.
- 15)** "The Back". Too much wood here will give you a hard, stubborn reed. Too little wood will cause the reed to collapse.
- 16)** If you grind here the reed will become more flexible and more vibrant. Also the high register is improved. The sound gets brighter.
- 17)** Pinch together the tip with your fingers and grind the front edge if the tonguing is too easy.

18) Improves the tonguing in the high register and the gives a freer low. The more you grind towards the middle of the reed (the marked lines), the darker, more flexibility and better striking and legato you will get.

19) If you feel that the sound is "dead" you can, as a last resort, drag the knife along these lines, but only a couple of times. This will give you more sting in the sound.

20) If you have a gauge, you can measure different points of thickness on the reed. This suggestion will give you a reed in good balance **with a lot of power** when using normal dense cane. At the same time, it gives you an idea of the incline from the tip of the reed to the back (when looking from the side). If you want a lighter reed, just evenly scrape down the whole surface so the relations will remain within the reed. Measure in the middle of the reed (the back) from the tip. Four mm into the reed the thickness is 0,55 mm, eight mm into the reed - 0,65 mm, twelve mm in - 0,70 mm, sixteen mm in - 0,80 mm, twenty mm in - 0,85 mm, and twenty-four mm in - 0,90 mm.

21) Holds back the sound, gives more resistance and darker sound. Improves upper register.

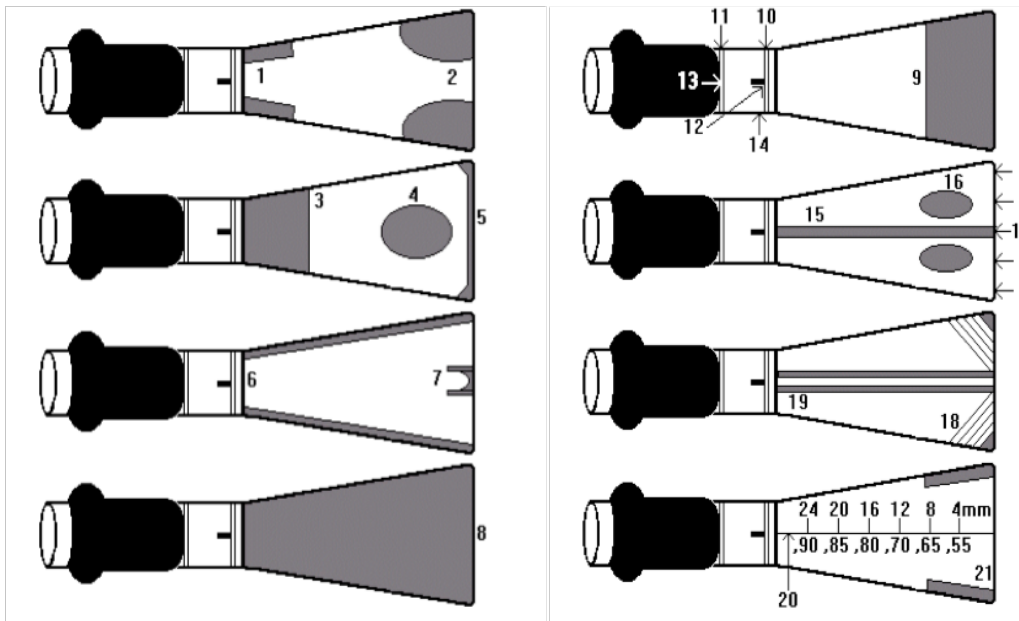

Reed Balancing Copyright © 1996 Christian Davidsson

PROBLEM	CAUSE	SOLUTIONS
The reed is hard to control. The player may sound buzzy or very flat, especially on 4 th line F and 3 rd space E	Too much vibration.	1. Try tightening first and/or second wires 2. Try squeezing from side to side on first and/or second wire (check tip opening after) 3. Last resort is to clip the tip 1mm.
The reed is hard to tongue. The reed may sound explosive.	Not enough vibration. Possibly tip is too open or thick.	1. Try squeezing the first wire from top to bottom to close the tip, then test. 2. Try using sandpaper at the tip 3. Try sanding the tip with sandpaper flat on a table.
The reed is hard to blow. The player may also sound sharp overall.	Not enough vibration	1. Try squeezing from top to bottom on first and/or second wires (check tip opening after). 2. Try using sandpaper in the heart and the back.

First Wire Adjustments

Side to Side	Top to Bottom
Opens the tip	Closes the tip
Adds resistance	Makes more flexible
Makes sharper	Makes flatter
Strengthens	Weakens
Makes tone darker	Makes tone brighter

Second Wire Adjustments

Side to Side	Top to Bottom
Closes the tip	Opens the tip
Adds resistance	Makes more flexible
Makes sharper	Makes flatter
Strengthens	Weakens
Makes tone darker	Makes tone brighter

TOOL SUPPLY LIST

REED ADJUSTING TOOLS

Holding Mandrel

Reed Knife

Pliers with wire cutters

Reamer

Plaque

Sandpaper (400 wet or dry)

Triangular Diamond File

REED MAKING TOOLS - TO FORM TUBE

Easel (dowel rod)

Ruler with 32nds of inches & mm

Pencil

X-acto Knife Blade #11

Sandpaper (320 wet or dry)

22 Gauge Brass Wire

End nippers

Cotton String

Forming Mandrel

Pliers

Drying Rack

REED FINISHING MATERIALS

Duco cement

Thread

Cane

GSP (Gouged, Shaped & Profiled) from womblewilliams.com

Cane, Reeds, Supply

- www.millermarketingco.com

- www.singindog.com

- www.rdgwoodwinds.com

- www.bartoncane.com

- www.forrestsmusic.com

- www.arundoreeds.com

- www.charlesmusic.com

- www.gobassoon.com

- www.christliebproducts.com

- www.jendeindustries.com

- www.mmimports.com

- www.mdreedproducts.com

MUSIC SOURCES

· **International Music Score Library Project (IMSLP)**

○ Provides free parts, scores, arrangements and recordings for thousands of pieces in public domain. This is a resource musicians use constantly!

· **TrevCo Varner Music**

○ TrevCo Varner Music is the "World's Foremost Purveyor of Fine Sheet Music for Double Reeds", with over 12,000 titles in stock.

· **JDW Sheet Music**

○ Music company that specializes in transcriptions for double reed ensembles of all combinations.